

WHAT I DO ON TOC3 FLOOR 2

Delta TechOps Component Engineering
Semester Accomplishments

Summer 2021
Madeleine Graham
Co-op Avionics



INTRODUCTION

NAME

Madeleine Graham
Palo Alto, CA
First Rotation Co-op

SCHOOL

Georgia Tech
BS AE Engineering '23
San Francisco State
BA Japanese '09



SF STATE



CAREER

English instructor - 2 years
Japanese instructor - 7 years

HOBBIES

Cello
Musical Theater
Rocketry
Mountain Climbing

FOR THE FUTURE

"...form a force for positive...global change..." -Delta

"...discover and expand knowledge for the benefit of humanity" - NASA



GOALS AND ACCOMPLISHMENTS

- 1) Draft an ER/A
- 2) Gain a general knowledge of a long-term career at DELTA
- 3) Create a good working relationship with my coworkers based on trust

- What do you want to accomplish? How ~~are~~ are you going to accomplish it?
How will you measure your accomplishment?

① ~~Learn~~ Draft an ER/A
- learn the system, first with an easy, doable assignment
- My name will be on an ER/A as a drafter

② Gain a general knowledge of a long-term career at DELTA / what's possible
- talk to employees who have similar backgrounds/aspirations
- talk to employees who have worked at DELTA for many years
- I'll understand job descriptions and

③ Create a good working relationship with my coworkers based on trust

GOALS AND ACCOMPLISHMENTS

My first ER/A: Shop 350 Request

130A	M15733-34-005	. FILTER (VC3117) INCLUDES ATTACHING PARTS NUT AND WASHER 1.4UF; 80V; 10A; MTEMP (NM P/N 5132-18340-1) (FL201-FL204) SUCCEEDS ITEM 130	4
------	---------------	--	---

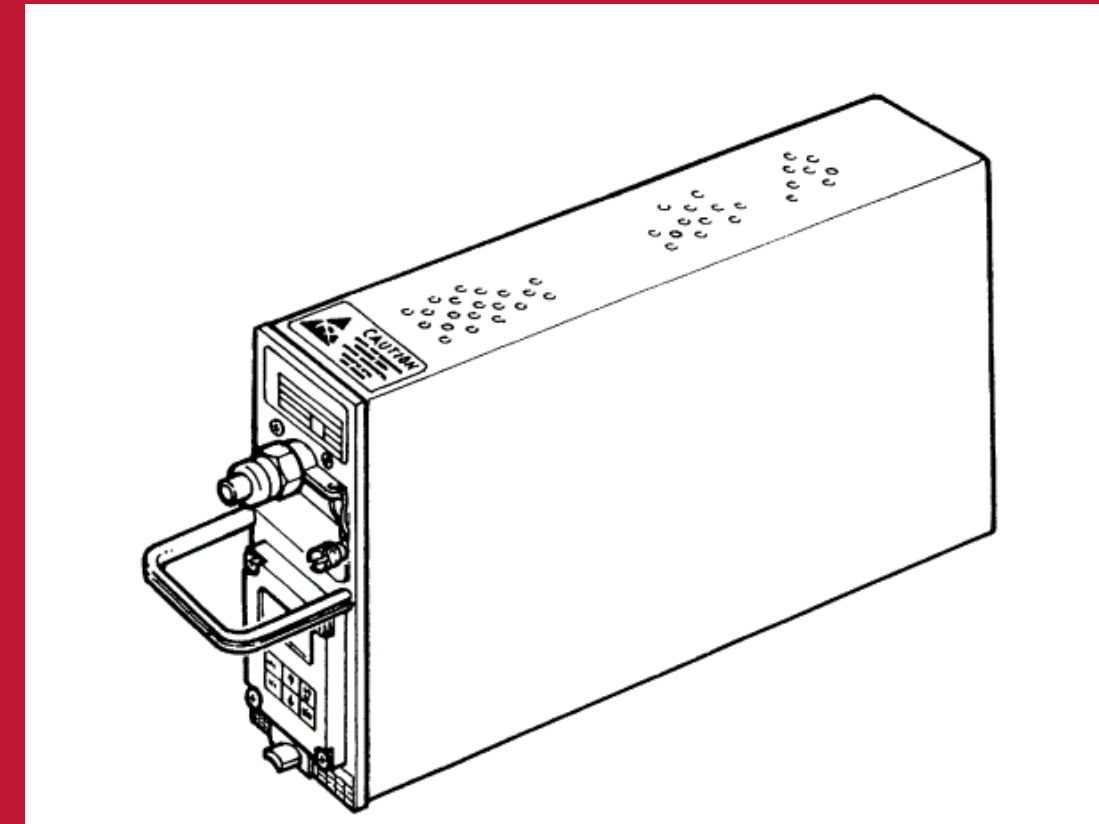
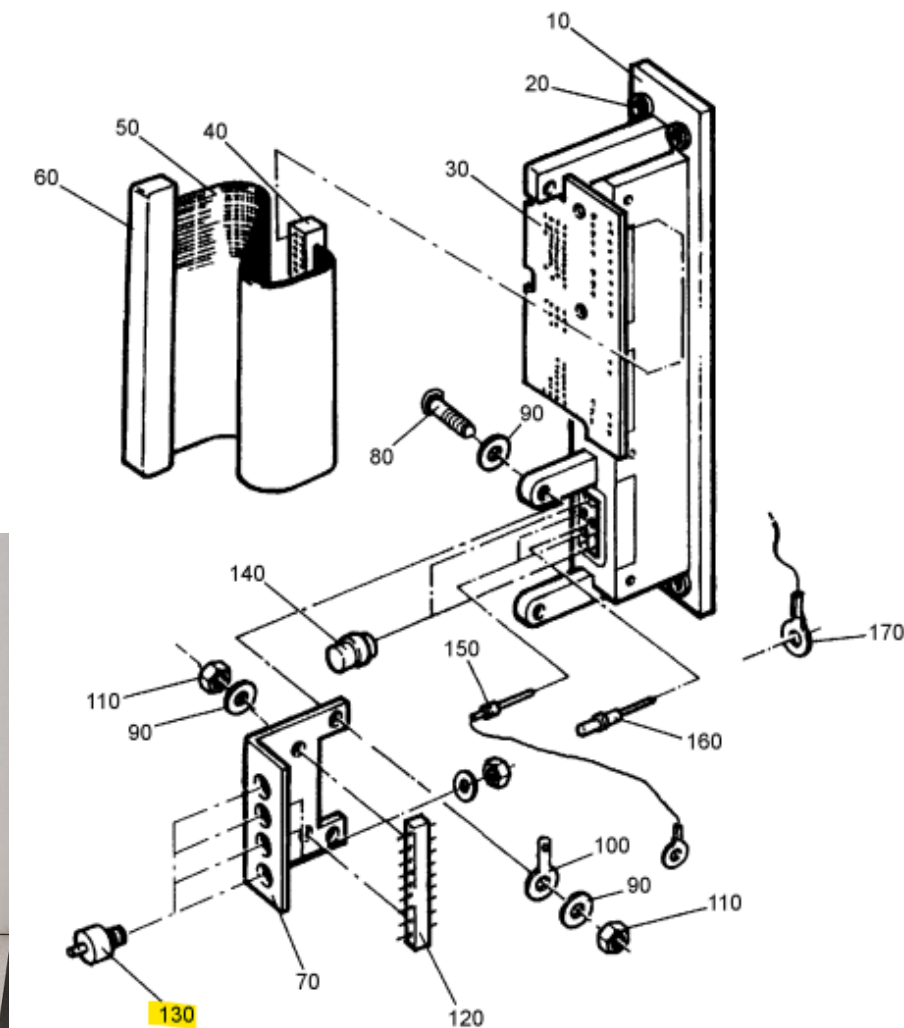

I apologize for the delayed response.

The correct P/N is M15733/38-0005

The item part number will be corrected in
Hope that helps.

Regards,
Andreas



GOALS AND ACCOMPLISHMENTS

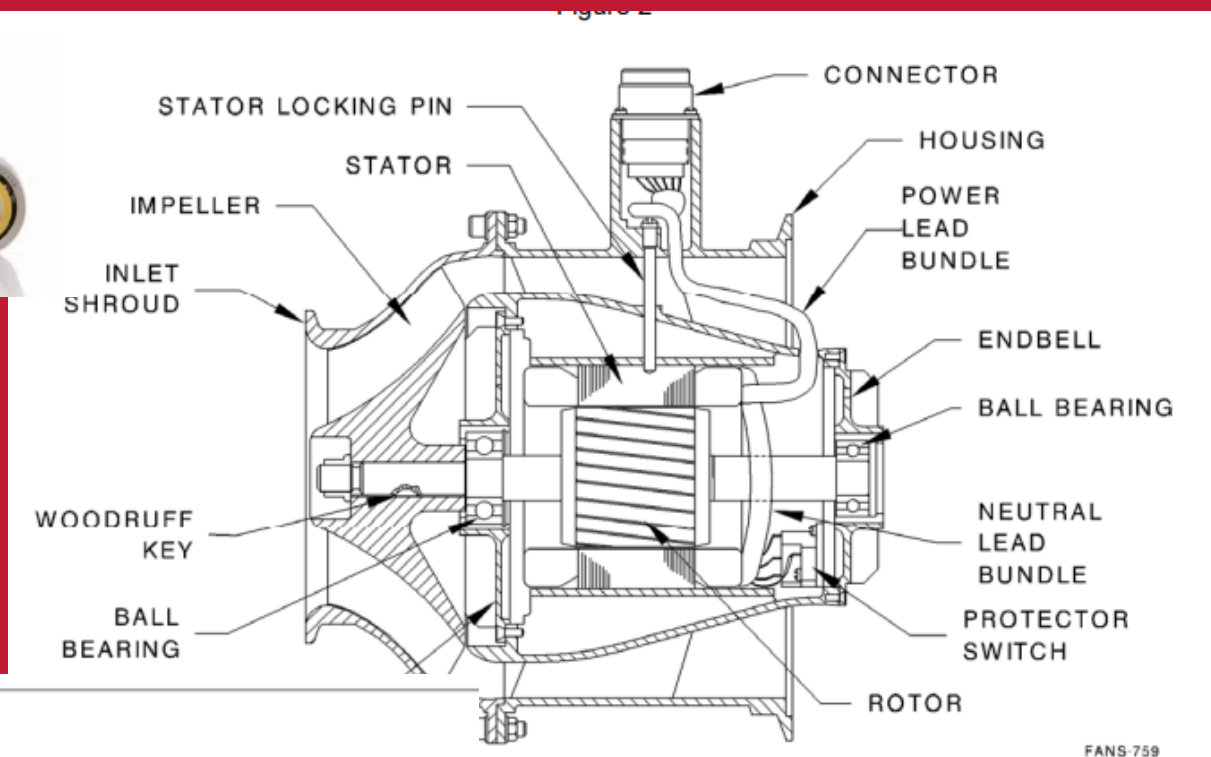

Ball Bearing part equivalency

Service Bulletin update - Enhanced Display Unit

145 Review of CMM 21-20-10
-8 ER/A's

Dear Philip,

Thank you for the clarification. Since PN 101FFTX1K6G33 is simply the manufactures PN for both PN 58861/X11374 I have no technical objection.

Mit freundlichen Grüßen / Best regards,

Bart Henuber | Service Engineer
Nord-Micro GmbH & Co. OHG
 a part of Collins Aerospace
 Victor-Slotosch-Strasse 20, 60388 Frankfurt am Main, Germany
 Tel: +49 6109 303 158 | Fax: +49 6109 303 615

View of Mixed Flow Fan Assembly
Figure 3

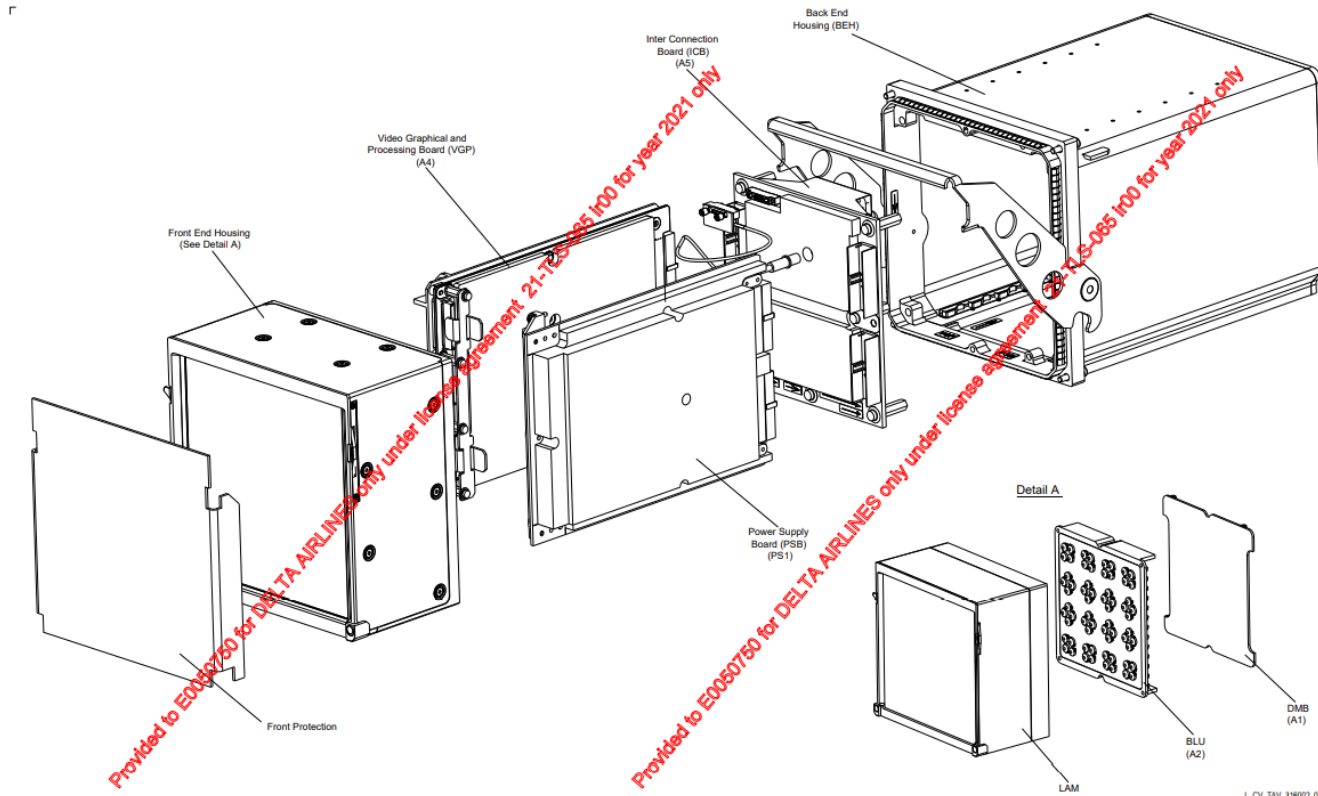

MM	Delta Page	TPCR	ER/A	ER/A Name	145 authorized?	Revision date	Notes	Updates	Date
-20-10	D1001-D1001B		403434-14		no	3/22/2011	CSVE	edited and updated via Webtop, needs approval	7/30/2021
-20-10	D7013		403434-14		no	3/23/2011		edited and updated via Webtop, needs approval	7/30/2021
-20-10	D6023		403434-14		no	3/23/2011		edited and updated via Webtop, needs approval	7/30/2021
-20-10	D6020		403434-14		no	3/23/2011	P.S. 900-2-4-1 No. 02	edited and updated via Webtop, needs approval	7/30/2021
-20-10	D6007		370354-14	Gasper Fan Balance	no	3/23/2011		edited and updated via Webtop, needs approval	7/30/2021
-20-10	D6020		403620-14		no	3/23/2011		waiting to submit to author	7/28/2021
-20-10	(Link)		524715-14		yes	3/22/2011			7/21/2021
-20-10	(Link)		416538-14		yes	3/22/2011	currently Rev A		
-20-10	D6023		416341-14		no	3/23/2011		finished ER/A - haven't uploaded yet or submitted to	7/28/2021
-20-10	D1004	12064			unknown	3/22/2011	Tech pubs change request	may have to look for this in area 51	
-20-10	D1005	12064			unknown	3/22/2011	Tech pubs change request	may have to look for this in area 51	
-20-10	D1006	12064			unknown	3/22/2011	Tech pubs change request	may have to look for this in area 51	
-20-10	D6001		416567-14 Rev A		no	3/22/2011	rev A only a word doc	created folder and downloaded all docs	
-20-10	D6001-D6001A		229637-14 Rev A		yes?	3/22/2011	no Rev A		
-20-10	D6001		403359-14 Rev B		no	3/22/2011	rev C is 145 approved		7/21/2021
	D10020		(parts list changes)		unknown				
	D10023		(parts list changes)		unknown				
	D10024		(parts list changes)		unknown				

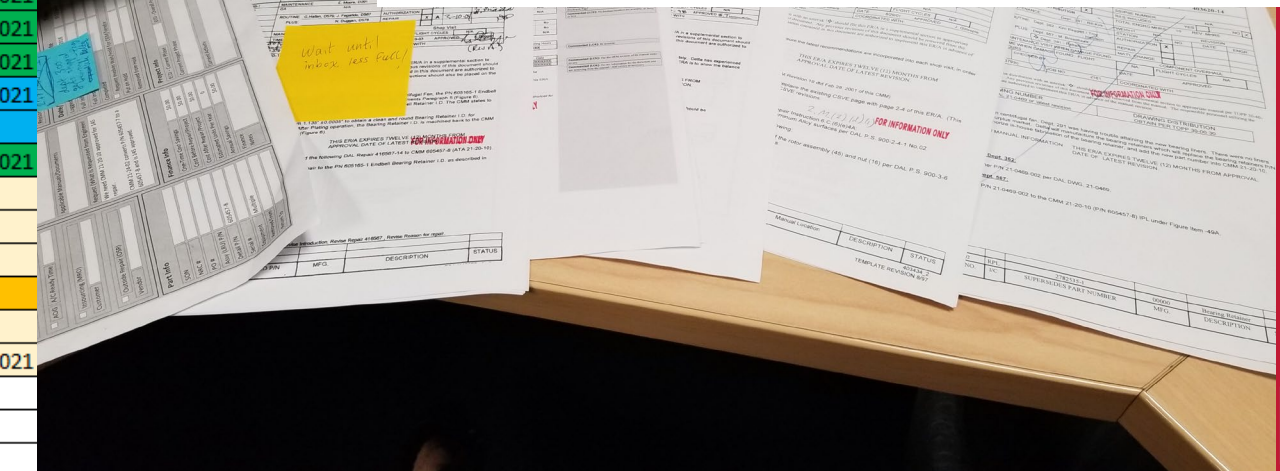
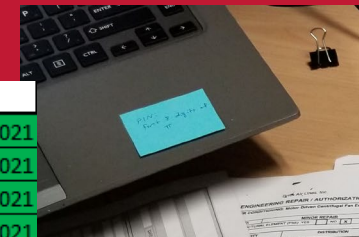

ELTA

GOALS AND ACCOMPLISHMENTS

Proactive Project...

Safety in Shop 298



OOPP PROJECT

SHOP 298

Electronic Engine Control (EEC)

-Wires send information - Voltage

Thermocouple

-Temperature creates a voltage

-At the end of harnesses: terminals

-K-Type - Alumel / Chromel

-Common, wires available

-OOPP - T2.95 terminal

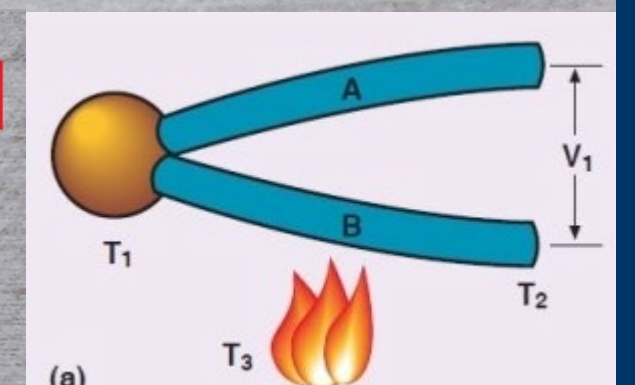
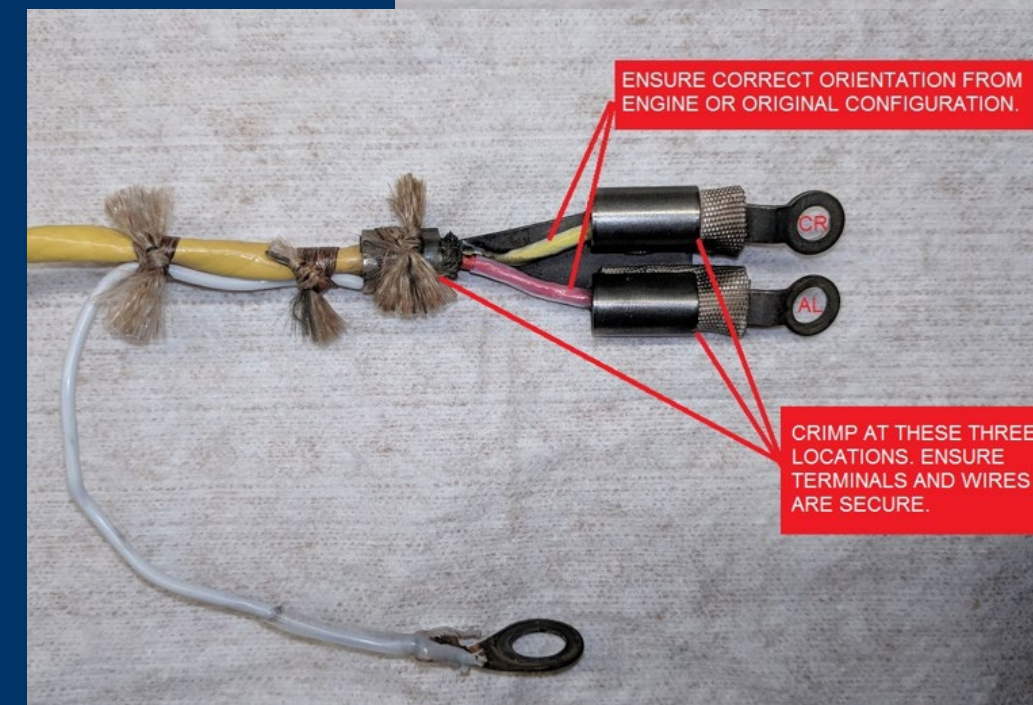
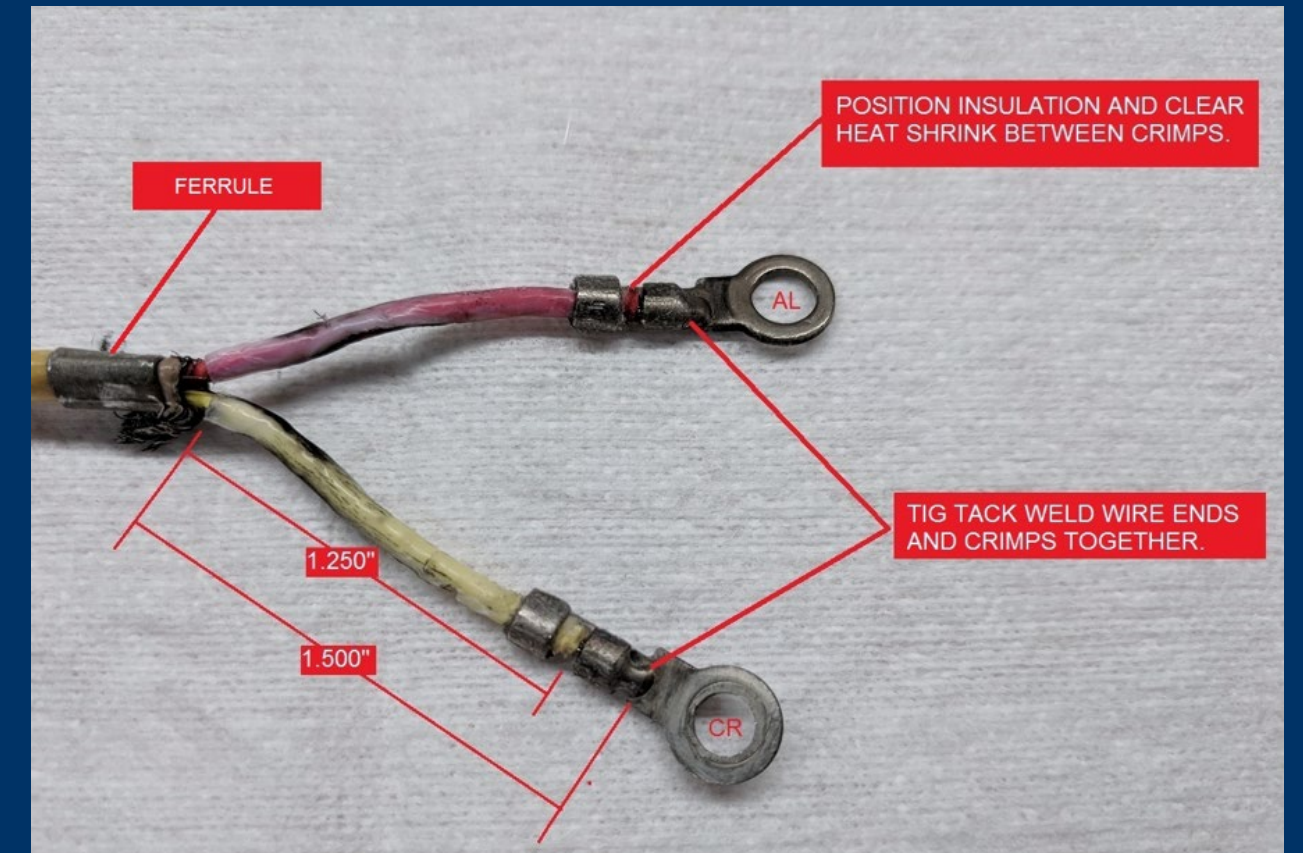

(a)

$$\nabla V = -S(T) \nabla T$$

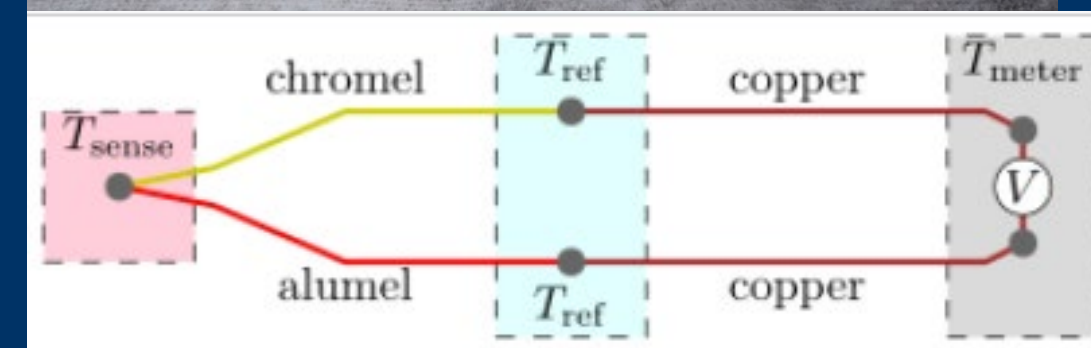

OOPP PROJECT

BACKGROUND

Shop 298 request from 2018
5 P/N's with varying lengths of wire
Long lead time

JetParts - OOPP
Replace 5 P/N with one at a lower cost
Already fabricates similar kits

Alumel/Chromel Shortage
Chinese company- Tankii Alloy

Back to JetParts

Failed the FAI
-Dimensional difference

Handover from previous Co-op

Table 1 -Delta, Jet Parts and OEM P/N Correspondence

OEM P/N	Description	Delta DWG	Jet Parts P/N
149516	Termination Assembly, T2.95B	73-0073 Rev. B	73-0073-101
151932	Termination Assembly, T2.95A	73-0073 Rev. B	73-0073-101
151933	Termination Assembly, T2.95B	73-0073 Rev. B	73-0073-101
158176	Termination Assembly, T2.95B	73-0073 Rev. B	73-0073-101
158329	Termination Assembly, T2.95A	73-0073 Rev. B	73-0073-101

but have been struggling to find a supplier for the material.

Sure, v
Please let me know the qty by kg you need monthly or per order.
Then we can quote you rightly.
Thank you
-

Best Regards,

Selina Miao
Deputy sales Manager

Tel: (+86)21 -5611 SHANGHAI TANKII ALLOY
3688 ext.801 MATERIAL CO., LTD.

Alloy Road, Baoshan
201909, China

could need to increase the length of the Al

OOPP PROJECT

MY PART IN THE STORY

Cost Savings analysis - Inventory Analyst

Handwritten notes on a yellow sticky note:

- 149516 - \$484.00
- 151932 \$642 - 3 ea
- 151933 \$545 - 2 year
- 158176 \$ 1929 - 11 ea
- 158329 \$ 946 - 16 ea

By:	M. Graham	Revised:	8/3/2021										
Part Number	Price per unit	Units per year (current)	Units per year 2019	Cost 2021	Cost 2019	Jetparts Part	Price per unit	Units per year (current)	Units per year 2019	Cost 2021	Cost 2019	Cost Savings Projection 2021	Cost Savings Projection 2019
149516	\$ 484.00	3	10	\$ 1,452.00	\$ 4,840.00	73-0073-001	\$ 550.00	35	69	\$ 19,250.00	\$ 37,950.00		
151932	\$ 642.00	3	6	\$ 1,926.00	\$ 3,852.00								
151933	\$ 545.00	2	2	\$ 1,090.00	\$ 1,090.00								
158176	\$ 1,929.00	11	16	\$ 21,219.00	\$ 30,864.00								
158329	\$ 946.00	16	35	\$ 15,136.00	\$ 33,110.00								
TOTAL		35	69	\$ 40,823.00	\$ 73,756.00					\$ 19,250.00	\$ 37,950.00	\$ 21,573.00	\$ 35,806.00

Handwritten notes on a yellow sticky note:

2019

- 149516 10 ea
- 151932 6 ea
- 151933 2 ea
- 158176 16 ea
- 158329 - 35 ea

\$ 35,806.00



TAKEAWAYS

Slow down...double, triple check

- Typos count, hand-offs matter

Wide variety of careers at Delta

- Different departments, career paths

Trust but verify

- Follow up with both technicians and OEM's

THANK YOU!

